

Sine wave profile 18/76

Guidelines for specification and installation



Contractor: Sinhor - QUARTZ-ZINC®

Sine wave cladding system in VM ZINC®.

- Horizontal or vertical laying on a metal or wood substructure
- Easy installation with overlapping and fixing
- Wave rhythms

This document applies exclusively to the specification and installation of the designated products or systems on building sites in the United Kingdom and the Republic of Ireland.

A Umicore brand





VM ZINC®

- is the brand name of rolled zinc products, transformed, produced and sold by Umicore.
- conforms to the EN 988.
- is a 99.995% electrolytic zinc, to which very small quantities of copper and titanium are added.



QUARTZ-ZINC®

Physical properties of VM ZINC®

Density: 7.18± 0.02 g/cm³

Linear expansion: 0.022 mm per m and per °C in the direction of rolling.



ANTHRA-ZINC®

VM ZINC®: a wide variety of surface appearances

QUARTZ-ZINC®

offers an appearance and texture close to the patina developed by natural VM ZINC®.

The grey tones of QUARTZ-ZINC® and its structural flexibility bring out the character of a building from the outset. Appreciated for refurbishment, its natural-looking colour blends well with existing construction materials.



Blue PIGMENTO®



Green PIGMENTO®



Red PIGMENTO®

Umicore organises practical training courses on the installation of VM ZINC® sine wave profile:

- Reserved for roofing and cladding professionals.
- Organised in a covered, specially equipped training centre.

Consult www.vmzinc.co.uk or telephone 01992 822288.

ANTHRA-ZINC®

Its name reflects the charcoal colour, offering many combination possibilities. ANTHRA-ZINC® is covered on both sides with a surface treatment with anti-corrosion agents. ANTHRA-ZINC® lends itself to highly structured architecture.

PIGMENTO®

The PIGMENTO® range is based on QUARTZ-ZINC to which mineral pigments are added. 3 colours are available. These colours, with their subtly changing reflections, inspire new ideas and blend perfectly with other materials. The coloured finish preserves the natural texture of pre-weathered zinc.

VM ZINC®: natural and recyclable

Zinc is 100% recyclable. More than 90% of the zinc used in the building industry is recycled. Less energy is required to produce it than the other principal metals. The energy balance is even more favourable in recycled zinc. This excellent result clearly proves the contribution of VM ZINC® to sustainable development.

Sine wave profile

Description of the system

Description

The system belongs to the rain-screen family (wall cladding installed on a ventilated air space).

This self-supporting system can easily be installed on a non-continuous supporting structure. The VM ZINC® sine wave profiles are installed on a metal framework fixed to the supporting structure (masonry or metal structure). The VM ZINC® sine wave profiles provide increased freedom of choice and design through the play of light and shadow on the cladding.

Area of applications

- New construction or refurbishment projects
- Flat or curved facade with large radius
- All types of buildings, in particular office and public buildings and collective housing.

Surface appearance

VM ZINC® sine wave profiles are manufactured from VM ZINC® in compliance with BS EN 988:1997. They are available in QUARTZ-ZINC®, ANTHRA-ZINC® and in PIGMENTO®.

Protective film

VM ZINC® sine wave profiles are delivered with a protective film which preserves them during installation on the site. As a general rule, immediately following

the installation of the VM ZINC®, the film should be removed from the entire surface at the same time thus guaranteeing an optimum aesthetic result.

Exception to this rule: when the profiles are close to the ground and there is still work to be done around the edges, etc.

Under no circumstances must the film be left on installed VM ZINC® for more than one month.

Storage recommendations

VM ZINC® sine wave profiles delivered on pallets must be stored in weatherproof conditions in a ventilated place so as to limit condensation which could change the appearance of the QUARTZ-ZINC®, the ANTHRA-ZINC® and PIGMENTO®.

The pallets must be slanted to allow water to run off.

All these precautions are necessary in order to avoid the formation of white rust.



▲ Contractor: Sinhor - QUARTZ-ZINC®

White rust forms on the surface of VM ZINC® when the latter comes into contact with humidity in the absence of carbon dioxide. In this case, the protective layer cannot form and white rust appears on the surface.

Unlike the patined layer, white rust provides no protection and leaves unattractive, indelible marks on the roof or facade. Consequently, we do not recommend installing panels that have been attacked by white rust.

Handling on the site

Materials are handled using supporting beams and cables.

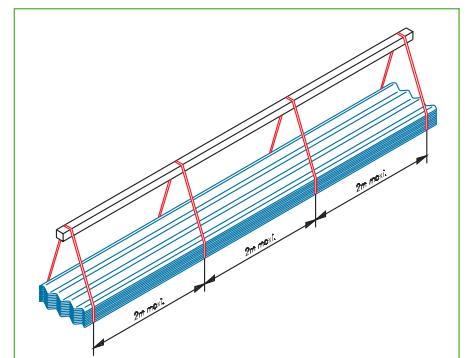

Sine wave profile

Description of the system



Arch. R. Mosimann - QUARTZ-ZINC®

Dimensions

Surface appearances	QUARTZ-ZINC® / ANTHRA-ZINC® / PIGMENTO®
Thickness	0.80 or 1 mm
Length	1.80 to 6 m
Wave length	76 mm
Wave depth	18 mm
Weight (0.80 mm)	6.9 kg/m ²
Weight (1.00 mm)	8.7 kg/m ²

Allowable windload resistance (N/m²)

	Max. Windload resistance in N/m ²					
	2 supports		3 supports		4 supports and more	
Thickness (mm)	0.80	1.00	0.80	1.00	0.80	1.00
distance between supports: 0.80 m	1440	1850				
distance between supports: 0.90 m	1130	1460				
distance between supports: 1.00 m	890	1160	1520	1960	1160	1490
distance between supports: 1.10 m	730	960	1140	1460	880	1130
distance between supports: 1.20 m	600	800	870	1120	710	930

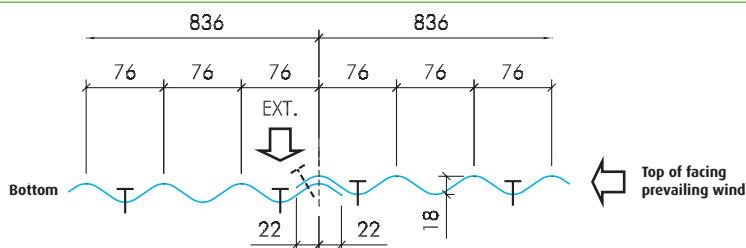

The following criteria were taken into account in determining these values:

- Deviation from flatness (1/200)
- Permanent deflection
- Failure value with a safety coefficient of ≥ 2 .

The distance between supports for this profile is limited to 1.30 m, with a screw at each support and in every second wave recess. Two screws are placed successively at the overlaps.

Pressure due to the effects of the wind is calculated on the basis of the official

standards for the calculation of loads due to the effect of wind on cladding. It takes into account the specific characteristics of the site, the situation of the project and the height of the building.

Pressure due to the effects of the wind on the facade is compared to the characteristic load values noted in the above table.

In a situation where the dynamic pressure of the project is greater than the values given in this guide, please contact your local VM ZINC® office.

Sine wave profile

Description of the system



Arch. Broberg - QUARTZ-ZINC® ▲

Authorised substructures

Authorised substructures can be in wood or metal (galvanised steel, aluminium). Their dimensions should be calculated according to the space between supports given on page 4 and take into account the wind loads for the project as well as the weight of the VM ZINC® sine wave profile cladding and the substructure.

< Ventilation

Contact with the outside air provides the CO₂ required to form the natural patina of VM ZINC®.

Without the presence of outside air VM ZINC® does not protect itself and if there is any condensation, a chemical reaction can occur. As a result there can be corrosion on the underside of the VM ZINC® which is not visible until holes appear on the outer skin.

The best ventilation is ensured by two continuous air inlets: one at the bottom and the other at the top of the cladding.

These air inlets are to be carefully spaced to ensure that the entire underside of the metal is ventilated.

Fixing fine mesh (< 2 mm) to all the air inlets will deter insects, rodents and birds from entering.

In most cases, a layer of insulating material is placed under the ventilated space.

There must be a very efficient rain barrier and the insulation panels must be sufficiently rigid and well anchored to their structure to prevent them from moving and blocking the ventilation space. Simply ensure that there is an airspace of 20 mm between the insulation and the edges of the profile. **There must be provision for a 20 mm ventilated space between the outside surface of the insulation material and the inside surface of the VM ZINC® sine wave profile.**

Before installation, the roofer must ensure that:

- the structure is dry, clean and free of any rubbish (nails, leaves, vegetation, etc.).
- The structure conforms (flatness, compatibility, etc.) to the specifications.

N.B.: The design of the framework and the dimensioning of its fixing components are not part of the range of services offered by VM ZINC®.

< Wooden fixing rail:

Minimum width of fixing rail to fix VM ZINC® sine wave profile: 60 mm, in a wood compatible with VM ZINC®.

< Metal fixing rail:

Minimum width of cladding rail (corner plate) to fix VM ZINC® sine wave profile: 60 mm.

Thickness: 1.5 mm for stainless steel and 2 mm for aluminium.

< Corner braces:

Angle brackets for vertical laying of VM ZINC® sine wave profile.

Corner plates for horizontal laying of VM ZINC® sine wave profile.

The corner plates have to allow the flatness of the support to be maintained, ensure the alignment of the fixing rails and the management of expansion in the case of expanding frameworks.



Arch. Burckhard & Partner - QUARTZ-ZINC® ▲

Sine wave profile

Description of the system

Expansion of VM ZINC®

Any work involving VM ZINC® must allow it to expand and contract freely.

The linear expansion of VM ZINC® is 0.022 mm per metre and per degree centigrade.

Example:

In the United Kingdom and the Republic of Ireland, the temperature range to bear in mind is from - 20°C in mid-winter to + 80°C on the surface of the metal in the sun at the height of the summer.

Assuming an ambient temperature of 20°C during installation, we have to take into account:

- An additional 60°C (expansion)
- 40°C less (contraction).

For a 6 metre long sine wave profile:
anticipate an $0.022 \text{ mm} \times 6 \times 60 = 7.92 \text{ mm}$ increase in length
anticipate $0.022 \text{ mm} \times 6 \times 40 = 5.28 \text{ mm}$ contraction.

Management of expansion of VM ZINC® sine wave profile

< Vertical laying

Fixed section at the top (maximum authorised gripped length: 3 m).
Expanding section at the bottom.

< Horizontal laying

Fixed section at the centre (maximum authorised gripped length: 3m).
Expanding section at the extremities.

Installation of fixed points with self drilling screws.

Sliding points, whose diameter is adapted to the expansion differential between the substructure and the cladding, to be pre-drilled in the VM ZINC® sine wave profile cladding.

About 2 mm greater than the diameter of the screws for wood and metal substructures (galvanised steel and aluminium).

Junctions

< Vertical laying

Transversal junction: VM ZINC® recommends flashing for junctions between profiles.

Longitudinal junction between profiles: by overlapping one wave top. See drawing page 4.

< Horizontal laying

Transversal junction: VM ZINC® recommends using a saddle piece for a junction between profiles.

Longitudinal junction between profiles: by overlapping one wave top.



Arch. ARCAU - ANTHRA-ZINC® ▲

Fixing screws

VM ZINC® recommends using lacquered screws using the RAL range as the reference for coating the head of the screw (RAL 7037 for QUARTZ-ZINC® and RAL 7022 for ANTHRA-ZINC®). VM ZINC® recommends using self-drilling screws for wood and steel.

The VM ZINC® sine wave profile is fixed using structural screws (1) at each support, in every second wave bottom. Where there is overlapping, two screws (1) are placed successively in addition to non-structural screws (2) which will be fixed between the structural fixing elements.

Note: The design of the framework and the dimensioning of its fixing elements are not part of the range of services offered by VM ZINC®.

Screws for wood framework

- drilling capacity to: 2,25 mm
- minimum dimensions: 4,8/35
- VM ZINC® recommends the use of 18/8 stainless steel screws for treated woods.
- zinc coated (gavalnised) steel screws can be used for untreated wood at the company's discretion.

The installation company must check that the loads are compatible with the stresses caused.

Screws for metal substructure:

- drilling capacity: 3,5 mm
- minimum dimensions: 5,5/25
- VM ZINC® recommends the use of 18/8 stainless steel screws.
- zinc coated (gavalnised) steel screws can be used for single skin cladding in

the case of zinc coated steel frameworks. This is at the company's discretion.

Seam screws

- drilling capacity to: 3,5 mm
- minimum dimensions: 4,8/20
- VM ZINC® recommends the use of 18/8 stainless steel screws.
- zinc coated (gavalnised) steel screws can be used for single skin cladding in the case of zinc coated steel frameworks. This is at the company's discretion.

Examples of makers and types of screws recommended by VM ZINC® :

Wood framework

- | | | | |
|----------|--------------------|-----------|--------------|
| > ETANCO | Drillnox star wood | stainless | round-headed |
| > ETANCO | Belvis bois | zcs* | round-headed |
| > SFS | TWS D12-A10 | stainless | round-headed |

Metal substructure

- | | | | |
|----------|----------------------|-----------|------------------|
| > ETANCO | Drillnox 3.5 Pi | stainless | hexagonal-headed |
| > ETANCO | Drillnox star 3.5 Pi | stainless | round-headed |
| > ETANCO | Belvis 5 | zcs* | round-headed |
| > SFS | SX3/SX4- D12-A10 | stainless | round-headed |

Seam screw

- | | | | |
|----------|----------------|-----------|------------------|
| > ETANCO | Drillnox 1 | stainless | hexagonal-headed |
| > SFS | SL2-B12 | stainless | round-headed |
| > ETANCO | Belvis Couture | zcs* | round-headed |

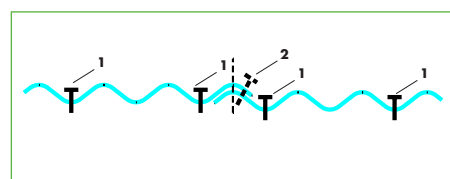

*zcs = zinc coated steel

Sine wave profile

Compatibility of VM ZINC[®] with wood, wood derivatives, glues and mastics

The compatibility of the wood with VM ZINC[®] must be analysed before specifying and fitting.

1. VM ZINC[®] on a wooden load-bearing structure

1.1. Wood varieties that may or may not be placed in contact with VM ZINC[®]

Compatible varieties	Incompatible varieties
Fir (red or white)	Larch
Spruce	Oak
Pine	Chestnut
Poplar	Red or white cedar
	Douglas pine
	All wood varieties with a pH < 5

1.2. Compatibility of wood treatment products with VM ZINC[®]

If the wood is treated, the compatibility of the treatment products with VM ZINC[®] must be checked (see table below).

Table of wood treatment products [*]			
Type of treatment	Components	Compatibility with VM ZINC [®]	Class
Non-fixing metal salts	Single component salts used in water (fluorite, boron or copper)	NO	C1
Metal fixing salts	Complex metal salts containing chromium to fix the active metals (CCA, CCB)	Study in progress (consult manufacturer)	C1 to C5
Organic products	Contain oil solvents	YES	C1 to C3
Emulsions	Use water as a vehicle combined with non-hydrosoluble synthetic substances	YES	C1 to C2
Combined products	Combine metal compounds (copper and boron) with synthetic molecules	To be determined (consult manufacturer)	C1 to C4
Creosote	Compound of active substances produced from hard coal distillation	To be determined (consult manufacturer)	C4

^{*} always refer to the manufacturer's notice for the product used.



Arch. Böge Lindner Architekten - QUARTZ-ZINC®

1.3. Compatibility of glues and mastics with VM ZINC®

If less traditional decking is used (e.g. wood panels), the compatibility of all the decking components (e.g. glues) with VM ZINC® should be checked, and, if applicable, the possibility of ventilating the under-surface of the VM ZINC® (see table below).

Table of glues and mastics ^{**}	
Compatible products	Incompatible products
Polyurethanes	Acetic silicones
Non-acetic silicones	Acid epoxides
MS Polymers	Ureas/melanin/phenol-formaldehyde (wood or panel glue)
	Acrylics (depending on the reagent used)

^{**} always refer to the manufacturer's notice.

2. Use of wood above VM ZINC®

Incompatible wood varieties may not be used above VM ZINC® elements (e.g. weather-boarding with incompatible boards or panels above the VM ZINC®). Incompatible timber wash, treatment products or tannic acids will quickly attack the zinc and cause the formation of unattractive stains.

Forbidden contacts

- Direct contact with products such as fresh concrete, plaster, bitumen, mortar and structures containing substances that are aggressive towards VM ZINC®.
- Contact with metals such as copper, unprotected or ungalvanised iron, unprotected natural lead.

Contact only allowed between VM ZINC® and:

- galvanised steel
- natural lead protected by a patinating oil
- FLEXUM® lacquered lead
- aluminium
- austenitic steel.

Subject

This document is intended for specifiers (building project architects and design teams) and users (companies responsible for installation on the building site) of the designated product or system.

Its purpose is to provide the main information, text and diagrams, relating to specification and installation (including supporting structures) and flashing installation.

Any use or specification outside the area of use and/or specifications contained in this manual requires specific consultation with the Umicore technical departments. This does not commit the latter to any responsibility with regard to the feasibility of the design or implementation of these projects.

Countries of application

This document applies exclusively to the specification and installation of the designated products or systems on building sites in the United Kingdom and the Republic of Ireland.

Qualifications and reference documents

Please note that the specification of all construction systems for a given building remains the exclusive responsibility of its design team, who must, in particular, ensure that the specified products are suitable for the purpose of the building and compatible with the other products and techniques used.

Please note that the correct use of this manual requires knowledge of VM ZINC® materials and of the zinc-roofing profession.

While construction is underway all standards in force must be respected.

Furthermore, Umicore offers training courses specifically for professionals.

Responsibility

The specification and installation of VM ZINC® products manufactured by Umicore are the sole responsibility of the architects and building professionals who must ensure these products are used in a way suited to the end purpose of the construction and that they are compatible with other products and techniques used.

The specification and installation of the products implies respecting the standards in force and the manufacturer's recommendations. In this regard, Umicore publishes and regularly updates specification and installation manuals for specific geographic areas and provides training courses. All the information on the latter can be obtained from the local VM ZINC® team.

Unless otherwise agreed in writing, Umicore cannot be held responsible for any damages resulting from a specification or installation that does not respect all of Umicore's specifications and the above standards and practices.